

With integrated booster  
and Tiltrotator

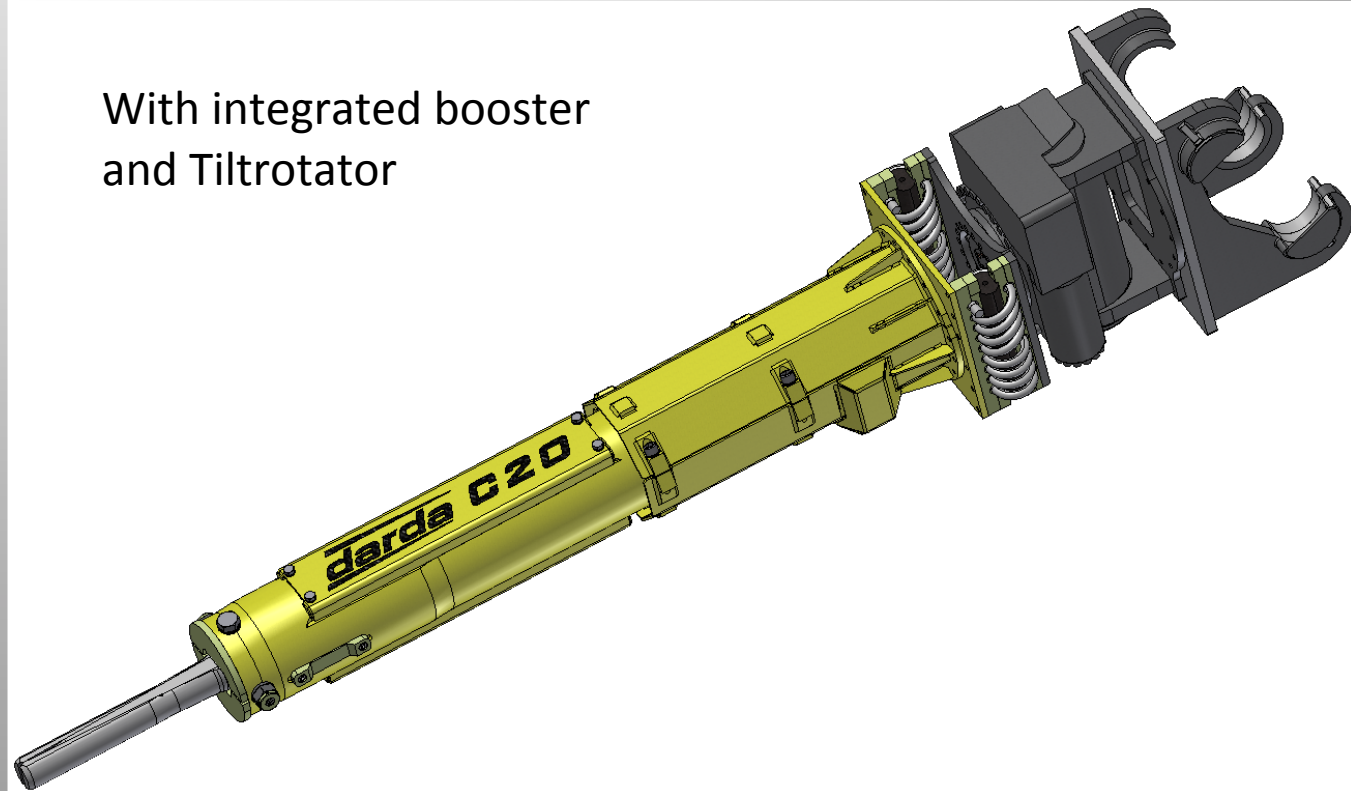

Technical data

Dimension

Application

With integrated booster  
and Tiltrotator

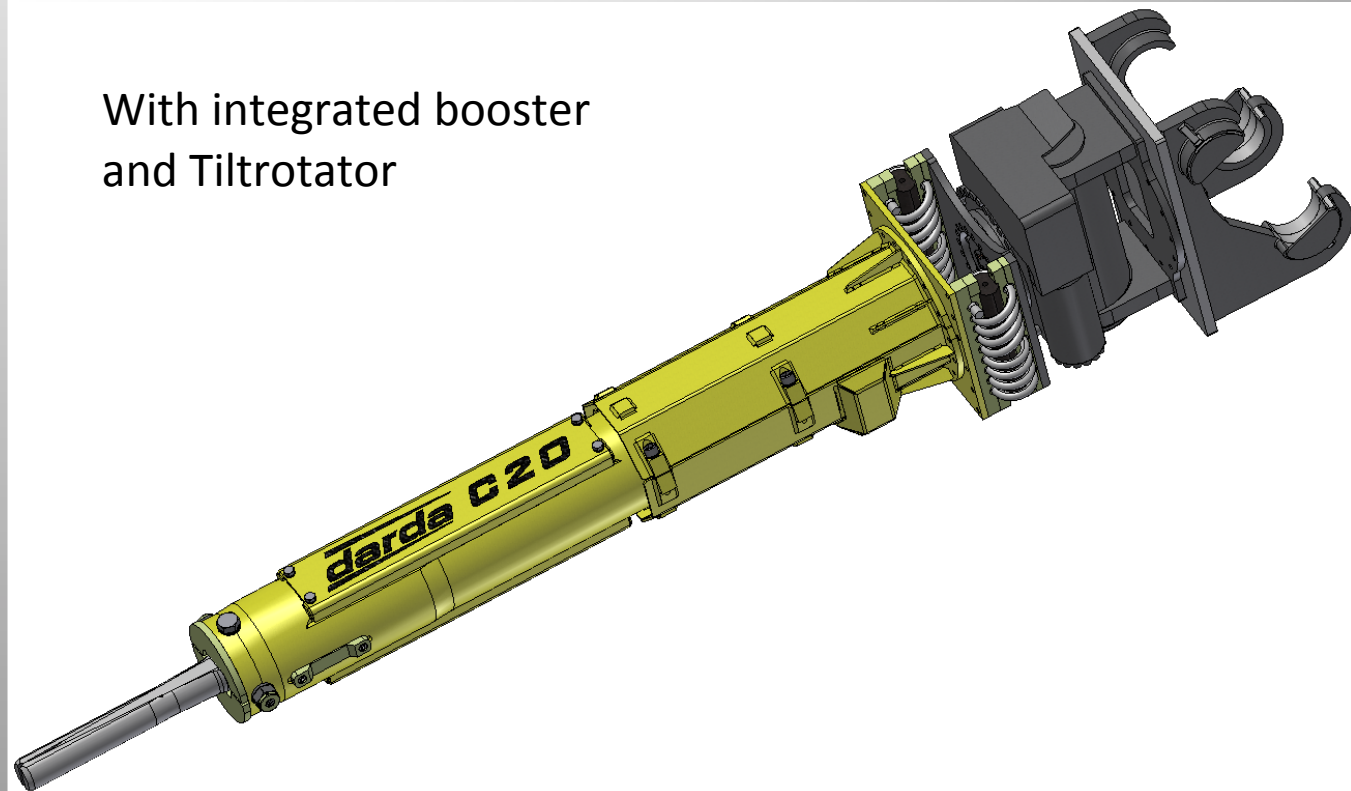

### Technical data

### Dimension

### Application

Splitting force theoretical	13,115 kN
Splitting distance	22 mm
Required drill hole	Ø64 - 65 mm
N - Wedge set length Drill hole depth	400 mm 650 mm
L - Wedge set length Drill hole depth	600 mm 850 mm
Weight without Tiltrotator Weight with Tiltrotator	approx. 265 kg approx. 450 kg
Connection pressure	min. 17.5 MPa / max. 27 MPa
Oil flow	max. 100 l/min

Technical data

Dimension

Application

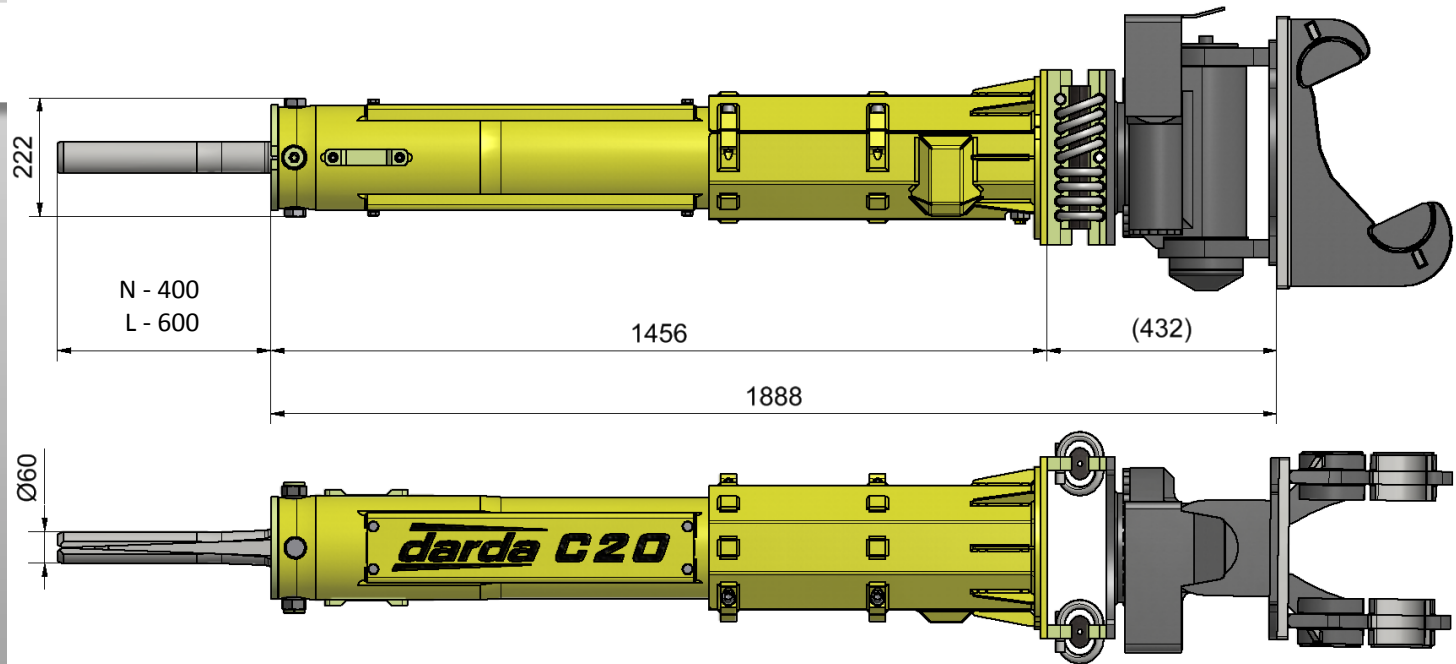

Technical data

Dimension

Application

